

<b>Product Name</b>	<b>CWM630 HSDPA Stamp Hole Module Hardware User Guide</b>
<b>Number of Pages</b>	<b>22</b>
<b>Produce Version</b>	<b>V1.3</b>
<b>Date</b>	<b>2016/4/19</b>

# **CWM630 HSDPA Stamp Hole Module Hardware User Guide**

---

V1.3



Shang Hai YUGE Information Technology co., LTD

All rights reserved

---



## Update records

<b>version</b>	<b>Date</b>	<b>Author</b>	<b>Description</b>
V1.0	20120522		Initial
V1.1	20120806		Increase selection instructions
V1.2	20120813		Fix some errors
V1.3	20160419		Change selection instructions



## Contents

Chapter 1. Introduction.....	4
1.1 Overview.....	4
1.2 Abbreviations.....	4
Chapter 2. Module review.....	5
2.1 Product Introduction.....	5
2.2 Module function block diagram.....	5
2.3 Main function of the module.....	6
Chapter 3. Technical specifications.....	7
3.1 Overall technical indicators.....	7
3.2 Radio frequency indicator.....	8
3.3 Power supply DC characteristics.....	8
Chapter 4 Interface definition.....	9
Chapter 5. Main function interface description.....	11
5.1 UART interface (optional function).....	11
5.2 USB interface.....	12
5.3 PCM interface (optional feature).....	13
5.4 AUDIO interface.....	14
5.5 USIM card interface.....	15
5.6 Control and general purpose I/O interface (optional feature).....	16
5.7 Power interface.....	17
5.8 Antenna socket interface.....	17
Chapter 6. structure.....	19
6.1 Structural size.....	19
Chapter 7. Selection guide.....	21



## Chart catalog

Figure 2-1 Functional Block Diagram of the CWM630 Module.....	5
Figure 5-1 UART interface and microprocessor connection reference design.....	11
Figure 5-2 Serial connection reference design.....	12
Figure 5-3 USB interface signal.....	12
Figure 5-4 USB interface reference design.....	13
Figure 5-5 PCM digital voice application reference design.....	14
Figure 5-6 Differential Audio Interface Reference Design.....	15
Figure 5-7 Single-ended audio interface reference design.....	15
Figure 5-8 USIM card interface reference design.....	16
Figure 5-9 LED lamp reference design.....	16
Figure 5-10 Antenna interface ESD protection recommende.....	18
Figure 6-1 Outline drawing of the CWM630.....	19
Figure 6-2 CWM630 module pin arrangement diagram (perspective view from the top of the module).....	20

## Table directory

Table 3-1 Overall technical indicators.....	7
Table 3-2 Radio frequency indicator.....	8
Table 3-3 DC characteristics of the power supply.....	8
Table 4-1 Interface definition.....	9
Table 5-1 UART Interface Definition.....	11
Table 5-2 USB Interface Definition.....	12
Table 5-3 PCM Interface Definition.....	13
Table 5-4 AUDIO Interface Definition.....	14
Table 5-5 USIM card interface definition.....	15
Table 5-6 Control and General I/O Interface Definitions.....	16
Table 5-7 LED_STATUS Status Indicator Table.....	17
Table 5-8 Power Interface Definition.....	17
Table 7-1 Model Description of CWM630 Module.....	21



# Chapter 1. Introduction

## 1.1 Overview

This document describes the functions, interfaces, technical specifications, appearance, and structure of the CWM630 module. It can help the R&D engineers using this module to provide design references.

## 1.2 Abbreviations

ADC	Analog-Digital Converter	模数转换
AFC	Automatic Frequency Control	自动频率控制
AGC	Automatic Gain Control	自动增益控制
ARFCN	Absolute Radio Frequency Channel Number	绝对射频信道号
B2B	Board to Board Connector	板对板连接器
BER	Bit Error Rate	比特误码率
CDMA	Code Division Multiple Access	码分多址
DAI	Digital Audio interface	数字音频接口
DAC	Digital-to-Analog Converter	数模转换
DSP	Digital Signal Processor	数字信号处理
DTR	Data Terminal Ready	数据终端准备好
EFR	Enhanced Full Rate	增强型全速率
EMC	Electromagnetic Compatibility	电磁兼容
EMI	Electro Magnetic Interference	电磁干扰
ESD	Electronic Static Discharge	静电放电
EVDO	Evolution Data Only	演进数据优化或者进化的数据
FR	Full Rate	全速率
GPRS	General Packet Radio Service	通用分组无线业务
HR	Half Rate	半速率
IMEI	International Mobile Equipment Identity	国际移动设备标识
ISO	International Standards Organization	国际标准化组织
PLL	Phase Locked Loop	锁相环
PPP	Point-to-point protocol	点到点协议
RAM	Random Access Memory	随机访问存储器
ROM	Read-only Memory	只读存储器
RTC	Real Time Clock	实时时钟
SMS	Short Message Service	短消息服务
UART	Universal asynchronous receiver-transmitter	通用异步接收/发送器
UIM	User Identifier Management	用户身份管理
USB	Universal Serial Bus	通用串行总线
VSWR	Voltage Standing Wave Ratio	电压驻波比



## Chapter 2. Module review

### 2.1 Product Introduction

CWM630 is a HSDPA module with a stamp hole patch package. It uses Qualcomm's latest WCDMA single-chip platform QSC6270, supports embedded operating systems such as WinCE/Linux, and has functions such as voice, SMS and high-speed data services. The CWM630 can be used in the following situations:

- ✧ Netbook, notebook
- ✧ PDA、MID
- ✧ Wireless POS machine
- ✧ Wireless advertising, media
- ✧ Wireless routing, switch
- ✧ Remote monitoring
- ✧ Smart meter reading
- ✧ lottery machine
- ✧ Other wireless terminals, etc.

### 2.2 Module function block diagram

The functional block diagram of the CWM630 module is shown in Figure 2-1 below:

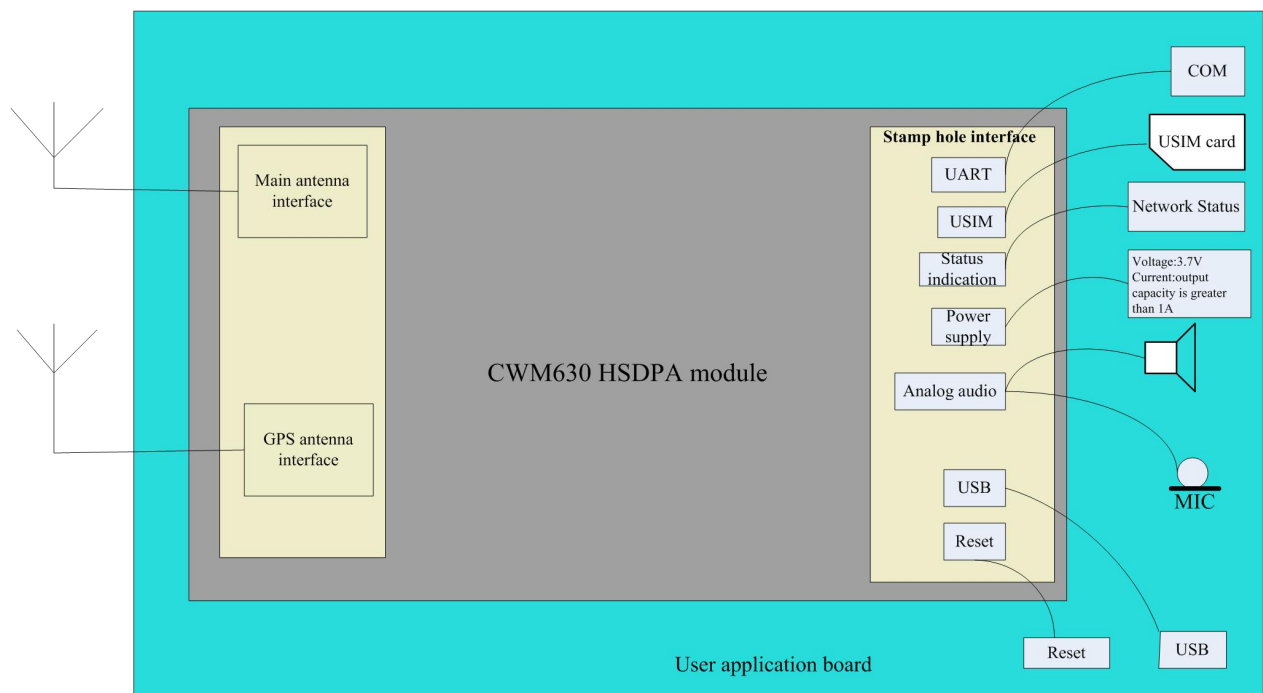

Figure 2-1 Functional Block Diagram of the CWM630 Module



## 2.3 Main function of the module

The main functions of the CWM630 module are as follows:

- ✧ Support UMTS/HSDPA/HSUPA Quad Band 850/900/1900/2100 band
- ✧ Support GSM/GPRS/EDGE Quad Band 850/900/1800/1900 frequency band
- ✧ Support GPS
- ✧ Support 1 USB 2.0 Highspeed interface
- ✧ Support 1 way RUIIM card interface (3.0V/1.8V)
- ✧ Support 1 8-wire UART interface
- ✧ Support 2 channels of analog voice and 1 channel of PCM/I2S interface (transmit digital voice)
- ✧ Support 2 GPIO
- ✧ Support 1 LED light control
- ✧ Extended AT instruction set supporting standard AT instruction set and domain



## Chapter 3. Technical specifications

### 3.1 Overall technical indicators

The overall technical specifications of the CWM630 module are shown in the following table:

Table 3-1 Overall technical indicators

Technical indicators	Description
External Interface	38 pin stamp hole interface
Working frequency	UMTS/HSDPA: Quad band, 850/900/2100MHz GSM/GPRS/EDGE: Quad band, 850/900/1800/1900MHz
Data rate	HSDPA: UL 384Kbps/DL 3.6Mbps WCDMA PS: UL 384kbps/DL 384kbps WCDMA CS: UL 64kbps/DL 64kbps EDGE: UL 236.8kbps/DL 236.8kbps GPRS: UL 53.6kbps/DL 53.6kbps GSM CS: UL 9.6kbps/DL 9.6kbps
Maximum transmit power	Class 4 (+33dBm ±2dB) for EGSM/GPRS 850 Class 4 (+33dBm ±2dB) for EGSM/GPRS 900 Class 1 (+30dBm ±2dB) for GSM/GPRS 1800 Class 1 (+30dBm ±2dB) for GSM/GPRS 1900 Class E2 (+27dBm ±2dB) for EDGE 850 Class E2 (+27dBm ±2dB) for EDGE 900 Class E2 (+26dBm ±2dB) for EDGE 1800 Class E2 (+26dBm ±2dB) for EDGE 1900 Class 3 (+24dBm +1/-3dB) for UMTS 2100, WCDMA FDD BdI Class 3 (+24dBm +1/-3dB) for UMTS 1900, WCDMA FDD BdII Class 3 (+24dBm +1/-3dB) for UMTS 900, WCDMA FDD BdVIII Class 3 (+24dBm +1/-3dB) for UMTS 850, WCDMA FDD BdV
Operating Voltage	3.3~4.2V, Recommended value 3.7V
Working current	Off: <50uA
	Standby: <3mA
	Maximum average: 1000mA
Size	31mm×39.5mm×2.6mm
Operating system	Windows 2000 Windows XP 32/64 Windows Vista 32/64 WinCE Linux
Weight	20g





Temperature	Normal operating temperature	-30°C ~ +70°C (Full parameter)
	Extended working temperature	-40°C ~ +85°C (Feature)
	storage temperature	-55°C ~ +125°C
Humidity		5% ~ 95%

### 3.2 Radio frequency indicator

The RF indicators of the CWM630 module are shown in the following table:

Table 3-2 Radio frequency indicator

	Upstream	Down	Power	Receiving sensitivity
GSM	824~849MHz	869~894MHz	33±2dBm	<-108.5dBm
	880~915MHz	925~960MHz	33±2dBm	<-108.5dBm
	1710~1785MHz	1805~1880MHz	30±2dBm	<-108.5dBm
	1850~1910MHz	1930~1990MHz	30±2dBm	<-108.5dBm
WCDMA	824~849MHz	869~894MHz	24+1/-3dBm	<-109dBm
	880~915MHz	925~960MHz	24+1/-3dBm	<-109dBm
	1850~1910MHz	1930~1990MHz	24+1/-3dBm	<-107dBm
	1920~1980MHz	2110~2170MHz	24+1/-3dBm	<-107dBm

### 3.3 Power supply DC characteristics

The DC characteristics of the CWM630 module power supply are shown in the following table.

Table 3-3 DC characteristics of the power supply

Parameter	Description	Min	Typical	Max	Unit
VCC	Module input power	3.2	3.7	4.2	V
VIH	Input high level	0.65*VDDIO		VDDIO+0.3	V
VIL	Input low level	-0.3		0.35*VDDIO	V
VOH	Output high level	VDDIO-0.45		VDDIO	V
VOL	Output low level	0		0.45	V
CIN	Input capacitance	-		7	pF

Here VDDIO = 2.6V/1.8V.



## Chapter 4 Interface definition

The CWM630 module interface definition is shown in the following table:

Table 4-1 Interface definition

Features	Pin	Signal name	Input/Output	Description	Remarks
SIM card interface	1	SIM_VCC	Output	2.85V/1.8V power supply	
	2	USIM_RST	Output	USIM card reset signal	
	3	USIM_CLK	Output	USIM card clock line	
	4	USIM_DATA	Two way	USIM card data cable	
Audio	6	EAR2_P	Output	Single-ended audio output channel 2	
	7	SPKR_OUT_P/ EAR1_OUT_P	Output	Differential audio output channel 1 positive	
	8	SPKR_OUT_N/ EAR1_OUT_P	Output	Differential audio output channel 1 negative	
	9	MIC2_P	Input	Single-ended audio input channel 2	
	10	MIC1_P	Input	Differential audio input channel 1 positive	
	11	MIC1_N	Input	Differential audio input channel 1 negative	
Reset	13	/PON_RESET	Input	Reset signal	Active low
Power supply	14	VBUS	Input	USB power	Recommended to hang
	15	VCHG	Input	Charger	If you do not need to charge the battery through the module, it is recommended to hang
	16	V_MAIN	Input	Module main power	3.2V-4.2V
	17	VREG_MSME	Output	Digital power supply	IO port voltage,



					2.6V/1.8V
	18	V_MAIN	Input	Module main power	3.2V-4.2V
	29	ON/OFF	Input	Switch control	Active low
UART	21	/CTS	Input	Allow reception	2.6V/1.8V , Active low
	22	RXD	Input	Module receives data from user	2.6V/1.8V
	23	TXD	Output	Module sends data to the user	2.6V/1.8V
	24	RI	Output	Ring tone	2.6V/1.8V
	25	RTS	Output	Send request	2.6V/1.8V , Active low
	26	/DTR	Input	Data terminal is ready	2.6V/1.8V , Active low
PCM	27	PCM_DOUT (DCD)	Output	PCM data output	2.6V/1.8V , Reuse with DCD
	28	PCM_SYNC (/DSR)	Output	PCM frame sync clock	2.6V/1.8V , Reuse with /DSR
	32	PCM_CLK	Output	PCM data clock	2.6V/1.8V
	33	PCM_DIN	Input	PCM data input	2.6V/1.8V
USB	30	USB_DP	Two way	USB data +	
	31	USB_DM	Two way	USB data -	
LED	34	STATUS_LED	Output	Module working status indicator	
Antenna	19	RF_ANT	Two way	Antenna interface	
	37	GPS_ANT	Input	GPS antenna interface	
Ground	5、12、 20、 35、 36、38	GND			



## Chapter 5. Main function interface description

### 5.1 UART interface (optional function)

Table 5-1 UART Interface Definition

Pin	Signal name	I/O properties	High value	Description
22	UART1_RXD	Input	2.6V/1.8V	UART1 data reception
23	UART1_TXD	Output	2.6V/1.8V	UART1 data transmission
21	UART1_CTS_N	Input	2.6V/1.8V	UART1 is ready to send
25	UART1_RTS_N	Output	2.6V/1.8V	UART1 request to send
24	UART1_RI_N	Output	2.6V/1.8V	UART1 ringing indication
26	UART1_DTR_N	Input	2.6V/1.8V	UART1 DTE is ready
27	UART1_DCD_N	Output	2.6V/1.8V	UART1 carrier detection
28	UART1_DSR_N	Output	2.6V/1.8V	UART1 DCE is ready
	GND			Ground

The UART interface supports 3-wire or 8-wire serial protocols.

The UART interface supports the following features:

- ✧ Software download upgrade
- ✧ Data communication
- ✧ AT Command
- ✧ Bluetooth

When the UART interface is directly connected to the microprocessor, the reference design is as follows. If the 3-wire connection is used, the RTS and CTS should be shorted. It should be noted that if the levels on both sides do not match, a level shifting device can be connected in series on the signal line or a bidirectional Schottky diode can be added.



Figure 5-1 UART interface and microprocessor connection reference design

The UART interface can also be connected to the standard RS232-C interface via an RS232 level shifting chip. The reference design diagram is as follows:

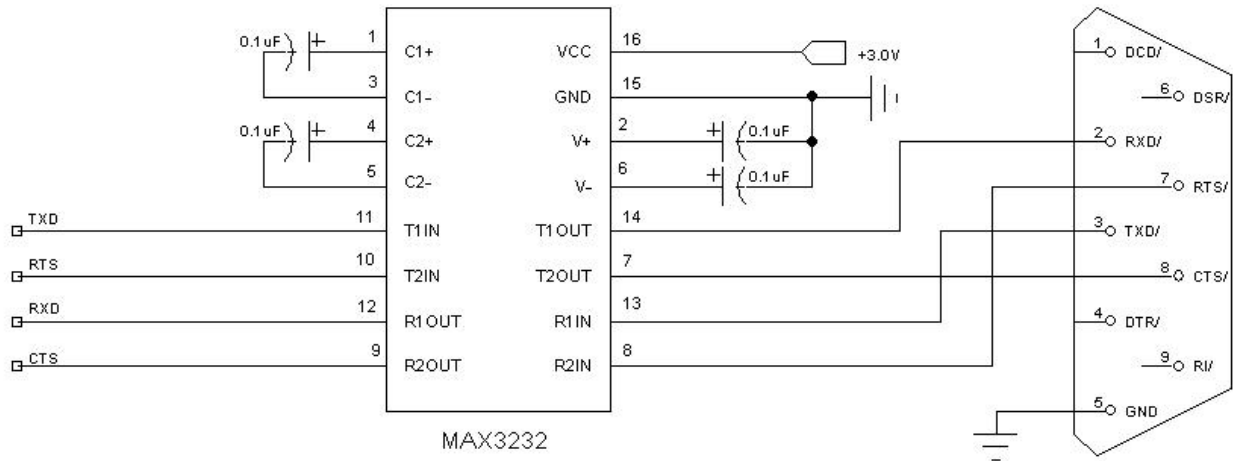

Figure 5-2 Serial connection reference design

Note: Figure 5-2 is just a connection diagram, and does not consider the level matching relationship.

## 5.2 USB interface

Table 5-2 USB Interface Definition

Pin	Signal name	I/O properties	High value	Description
31	USB_D-	Two way	3.3V	USB data cable -
30	USB_D+	Two way	3.3V	USB data cable +
	GND			Ground

The USB interface supports USB 2.0 High speed and Full speed. Note that the CWM630 can only be a slave device.

The USB interface supports the following features:

- ✧ Software download upgrade
- ✧ Data communication
- ✧ AT Command

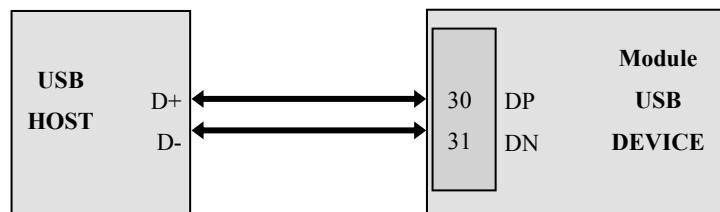

Figure 5-3 USB interface signal

The USB interface reference design is shown below. Note that the ESD protection device should be added to the data line.

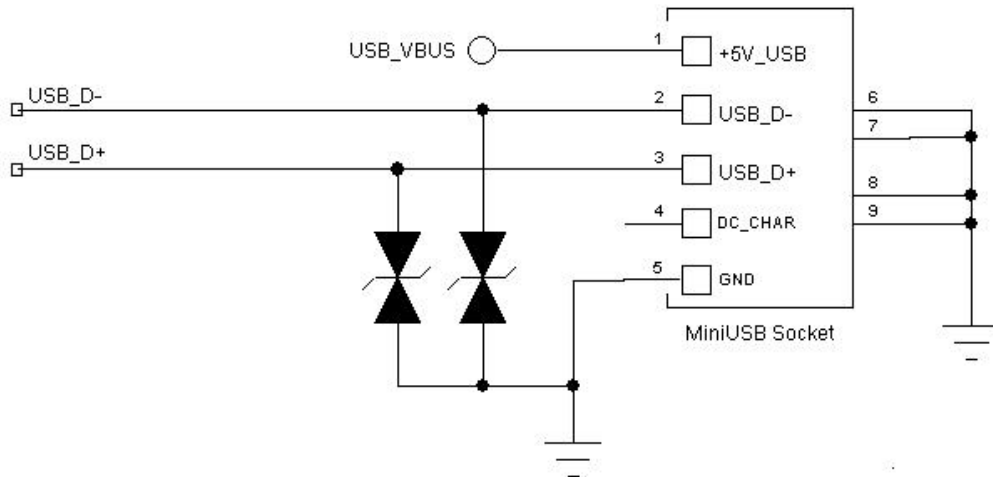

Figure 5-4 USB interface reference design

Note:

1. USB interface reference design diagram, you should pay attention to the ESD protection device should be added to the data line. The USB trace design of the DTE interface board needs to strictly follow the USB2.0 protocol requirements, and the differential trace has a control impedance of  $90\ \Omega$ .

2. The USB bus supply voltage is provided internally by the module and does not need to be provided externally. At the same time, since the USB interface of the module does not provide USB bus power, the module can only be used as a slave device of the USB bus.

### 5.3 PCM interface (optional feature)

Table 5-3 PCM Interface Definition

Pin	Signal name	I/O properties	High value	Description
32	PCM_CLK	B	2.6V/1.8V	PCM clock
27	PCM_DOUT	O	2.6V/1.8V	PCM data output
33	PCM_DIN	I	2.6V/1.8V	PCM data input
28	PCM_SYNC	B	2.6V/1.8V	PCM synchronization
	GND			Ground

This interface is a PCM/I2S interface and can support the following functions:

- ✧ Bluetooth
- ✧ Codec interface
- ✧ DAC/ADC interface

The following figure shows an application of the PCM interface for digital voice transmission. It is converted to analog voice by an external Codec chip, and then connected to the MIC and RECEIVER.





interfaces.

The reference design of the differential audio input and output interface is as follows:

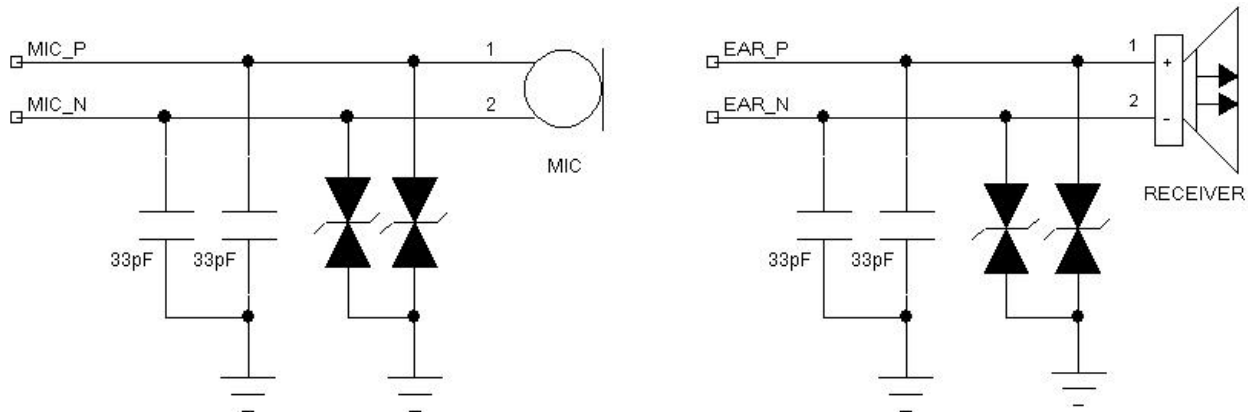

Figure 5-6 Differential Audio Interface Reference Design

The differential audio channel can also work in single-ended mode, such as an external headphone jack. The single-ended audio interface is preferably packaged on the outside of the PCB design. The audio input and the audio output need to be separated to prevent crosstalk. At the same time, keep away from power, RF, antenna and other circuits. In addition, it is recommended to add ESD protection devices at the interface.

The reference design diagram for the single-ended audio interface is as follows:

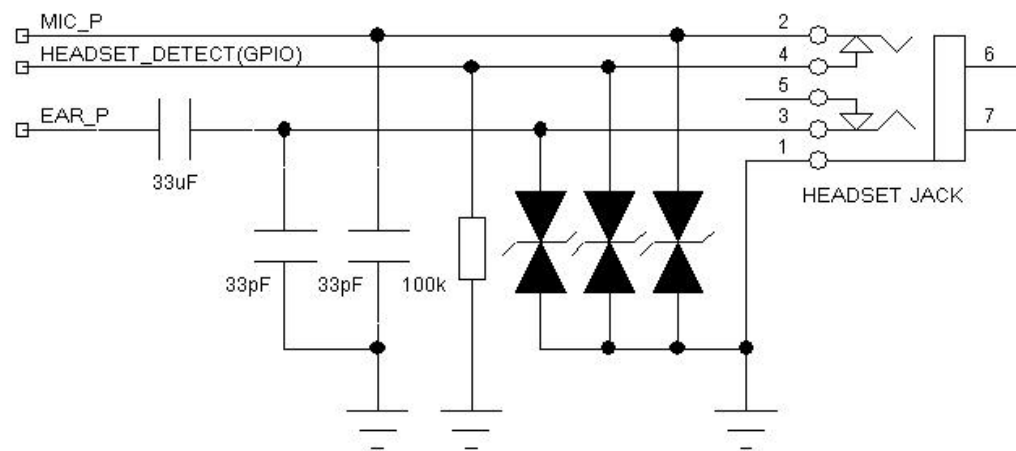

Figure 5-7 Single-ended audio interface reference design

## 5.5 USIM card interface

Table 5-5 USIM card interface definition

Pin	Signal name	I/O properties	High value	Description
1	SIM_VCC	Output	1.8V/2.85V	USIM card power supply
4	SIM_DATA	Two way	1.8V/2.85V	USIM card data
3	SIM_CLK	Output	1.8V/2.85V	USIM card clock
2	SIM_RESET	Output	1.8V/2.85V	USIM card reset
	GND			Ground

The CWM630 module can be connected to a 3.0V/1.8V RUIIM card and can be





automatically detected. It is recommended to connect 33  $\mu$  capacitors between USIM\_CLK, USIM\_DATA, USIM\_RESET and GND to filter out the interference of RF signals, and connect 33 ohm resistors in series on USIM\_CLK, USIM\_DATA, USIM\_RESET. Also, note that the ESD protection device is placed next to the USIM deck.

The USIM card interface reference design diagram is as follows:

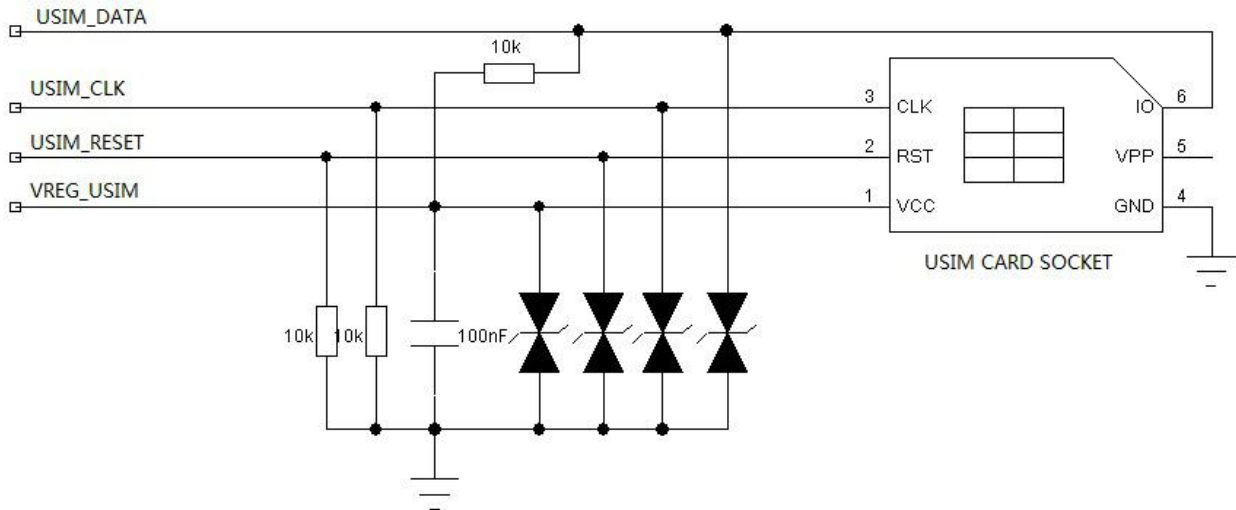

Figure 5-8 USIM card interface reference design

## 5.6 Control and general purpose I/O interface (optional feature)

Table 5-6 Control and General I/O Interface Definitions

Pin	Signal name	I/O properties	High value	Description
29	PWR_ON_N	Input	$\sim$ VBAT-0.3V	Low level on, off
34	LED_STATUS	Current input	3.3V	Work status light, "low" is valid, the default is "high", Current sink.
13	RESET_IN	Input	1.8V	Module reset control pin, low effective
	GND			Ground

RESIN\_N: The module can be reset by pulling this pin low for 50ms. This pin is sensitive to interference and should be protected when wiring.

LED\_STATUS: This pin is controlled by SINK type current source mode. The maximum current that can flow in is 40mA. When external LED lamp is connected, the current limiting resistor should be connected in series. The resistance value can be calculated from the rated voltage/rated current of the selected LED lamp.

The reference design of the LED light interface is as follows:

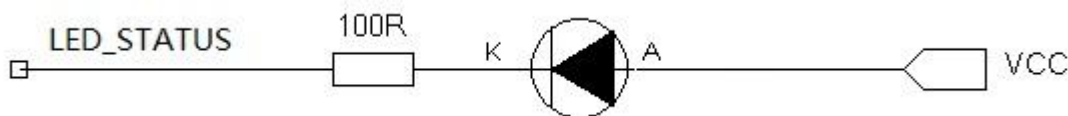

Figure 5-9 LED lamp reference design

LED\_STATUS is the working status indicator of the CWM630 module, which is controlled by the module software. The status table is as follows:



Table 5-7 LED\_STATUS Status Indicator Table

CWM630 working mode	LED display status
Search network	Single flash (cycle is 3s)
Successfully registered network, but in idle state (ie, not in call or data transfer state)	Double flash (cycle is 3s)
Call or data transfer status	Fast flashing (cycle is 0.2s)

## 5.7 Power interface

Table 5-8 Power Interface Definition

Pin	Signal name	I/O properties	High value	Description
16	VBAT	power input	3.2V~4V	main power
18	VBAT	power input	3.2V~4V	main power
14	USB_VBUS	power input	5V	Recommended to hang
15	VCHG	power input	5V	If you do not need to charge the battery through the module, it is recommended to hang
17	VREG_MSME	Power Output	2.6V/1.8V	Power supply for external interface OC gate
1	SIM_VCC	Power Output	1.8V/2.85	SIM card power supply
	GND			Ground

The maximum average power consumption of the CWM630 module is about 1000mA. It is recommended to use an LDO or a switching power supply of 1.5A or more. In order to maintain the instantaneous voltage stability during operation, it is recommended to add a large storage capacitor, such as 220uF tantalum capacitor, to the power port of the motherboard.

## 5.8 Antenna socket interface

The module contains two RF antenna interfaces, the main set and the GPS. Connected to the main antenna interface (M) and the GPS antenna interface (G) must be a 50 ohm characteristic impedance trace and antenna.

According to the user's circuit board routing to debug the parameters of each device, you can connect 68~100nH inductor to the ground to prevent static electricity. Pay attention to the impedance matching and antistatic or lightning strike of the antenna.

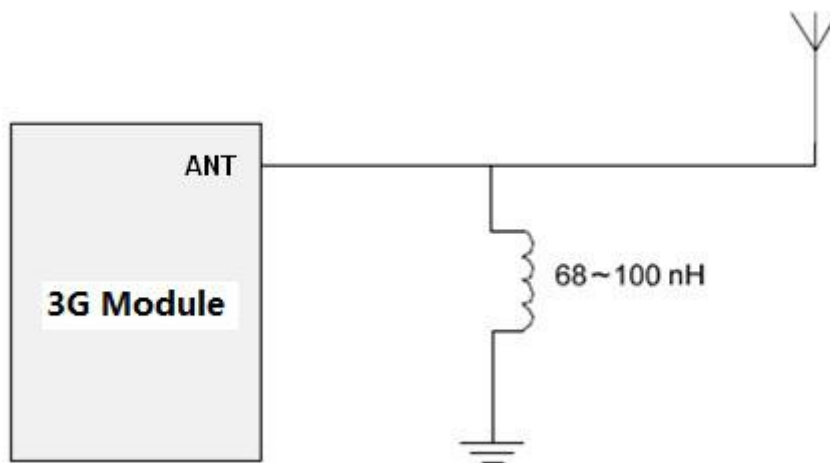

Figure 5-10 Antenna interface ESD protection recommende



## Chapter 6. structure

### 6.1 Structural size

The outline drawing of the CWM630 module is as follows:



Figure 6-1 Outline drawing of the CWM630

The pin arrangement and module dimensions of the CWM630 module are shown in Figure 6-2 (Note: This is a perspective view from the top of the module shield):

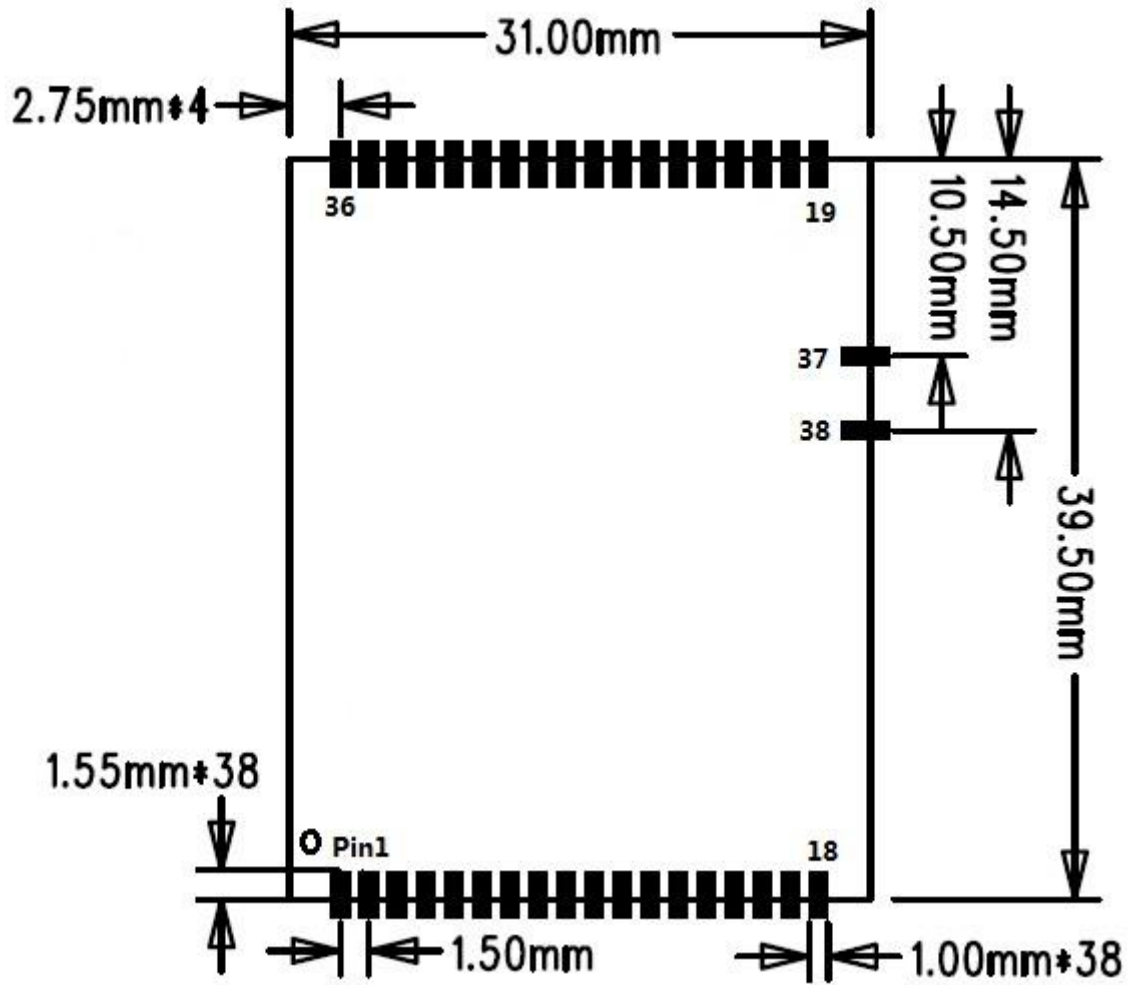

Figure 6-2 CWM630 module pin arrangement diagram (perspective view from the top of the module)



## Chapter 7. Selection guide

The product name and product definition of the CWM630 series module are as follows. The CWM960 is the default model and supports the WCDMA2100 band and the GSM full band.

When a multi-band module is required, as shown in the following table, each WCDMA band has a code that can be arbitrarily combined according to the required band code. (Note: W850 and W900 cannot be supported at the same time, all models support GSM full frequency by default)

A: represents the WCDMA 2100MHz band

B: stands for WCDMA1900MHz band (this model does not support 1900M)

C: represents the WCDMA 900MHz band

D: represents WCDMA 850MHz frequency band

Table 7-1 Model Description of CWM630 Module

Model	Frequency band	Whether with GPS	Whether to support voice	IO port voltage	Remarks
CWM630	UMTS/HSDPA:2100 MHz GSM/GPRS/EDGE: 850/900/1800/1900 MHz	No	Yes	2.6V/1.8V	The default interface level is
CWM630 AC	UMTS/HSDPA: 2100/ 900 MHz GSM/GPRS/EDGE: 850/900/1800/1900 MHz	No	Yes	2.6V/1.8V	1.8V. If 2.6V interface level is
CWM630 AD	UMTS/HSDPA: 2100 / 850 MHz GSM/GPRS/EDGE: 850/900/1800/1900 MHz	No	Yes	2.6V/1.8V	required, it needs to be marked.