

Product Name	CWM600 HSDPA Module Hardware User Guide
Number of Pages	26
Produce Version	V1.9
Date	2015/1/20

CWM600 HSDPA Module Hardware User Guide

V1.9



Shang Hai YUGE Information Technology co., LTD

All rights reserved



Update records

version	Date	Author	Description
V1.0	20110714		Initial
V1.1	20111114		Modify UART port description error
V1.2	20111121		Modify the indicator status description
V1.3	20111216		Modify the UART port description
V1.4	20120505		Modify the description of the diversity antenna, etc.
V1.5	20120522		Correction section description error
V1.6	20120628		Modify the interface level description
V1.7	20120806		Increase selection guide
V1.8	20150102		Change selection guide
V1.9	20150120		Modify module operating voltage and leakage current



Contents

Chapter 1. Introduction.....	4
1.1 Overview.....	4
1.2 Abbreviations.....	4
Chapter 2. Module review.....	6
2.1 Product Introduction.....	6
2.2 Module block diagram.....	6
2.3 Main function of the module.....	7
Chapter 3. Technical specifications.....	8
3.1 Overall technical indicators.....	8
3.2 Radio frequency indicator.....	9
3.3 Power Supply DC Characteristics.....	9
3.3.1 Power/IO Level Characteristics.....	9
3.3.2 Working current.....	10
Chapter 4 Interface definition.....	11
Chapter 5. Main function interface description.....	14
5.1 UART interface (optional function).....	14
5.2 USB interface.....	15
5.3 PCM interface (optional feature).....	16
5.4 AUDIO interface.....	17
5.5 USIM card interface.....	18
5.6 Control and general purpose I/O interface (optional feature).....	19
5.7 Power interface.....	20
5.8 Antenna socket interface.....	21
Chapter 6. structure.....	22
6.1 Structural size.....	22
6.2 Mini PCI Express connector.....	22
6.3 RF connector.....	23
Chapter 7. Selection guide.....	25



Chart catalog

Figure 2-1 CWM600 module block diagram.....	6
Figure 5-1 UART interface and microprocessor connection reference design.....	14
Figure 5-2 Five-wire serial port reference design.....	15
Figure 5-3 8-wire serial port reference design.....	15
Figure 5-4 USB interface reference design.....	16
Figure 5-5 PCM digital voice application reference design.....	17
Figure 5-6 Differential Audio Interface Reference Design.....	18
Figure 5-7 Single-ended audio interface reference design.....	18
Figure 5-8 USIM card interface reference design.....	19
Figure 5-9 LED lamp reference design.....	20
Figure 5-10 Antenna Interface ESD Protection Reference Design.....	21
Figure 6-1 CWM600 series module structure size.....	22
Figure 6-2 PCI Express Mini Card Connector.....	23
Figure 6-3 Antenna connector size.....	23
Figure 6-4 Antenna connector mating plug.....	24

Table directory

Table 1-1 Abbreviations.....	4
Table 3-1 Overall technical indicators.....	8
Table 3-2 Radio frequency indicator.....	9
Table 3-3 Power/IO Level DC Characteristics.....	9
Table 3-4 Working current of CWM600 series module.....	10
Table 4-1 Interface definition.....	11
Table 5-1 UART Interface Definition.....	14
Table 5-2 USB Interface Definition.....	15
Table 5-3 PCM Interface Definition.....	16
Table 5-4 AUDIO Interface Definition.....	17
Table 5-5 USIM card interface definition.....	18
Table 5-6 Control and General I/O Interface Definitions.....	19
Table 5-7 LED_WWAN_N Status Indicator Table.....	20
Table 5-8 Power Interface Definition.....	20



Chapter 1. Introduction

1.1 Overview

This document describes the functions, interfaces, technical specifications, appearance, and structure of the CWM600 series modules. It can help the R&D engineers using this module to provide design references.

1.2 Abbreviations

Table 1-1 Abbreviations

AMR	Adaptive Multirate	自适应多速率
BER	Bit Error Rate	误码率
BTS	Base Transceiver Station	基站收发信台
CS	Circuit Switched (CS) domain	电路域
CSD	Circuit Switched Data	电路交换数据
DCE	Data circuit—terminating equipment	数据电路终端设备
DTE	Data terminal equipment	数据终端设备
DTR	Data Terminal Ready	数据终端就绪
EFR	Enhanced Full Rate	增强型全速率
EGSM	Enhanced GSM	增强型 GSM
EMC	Electromagnetic Compatibility	电磁兼容性
ESD	Electrostatic Discharge	静电释放
FR	Frame Relay	帧中继
GMSK	Gaussian Minimum Shift Keying	高斯最小移频键控
GPRS	General Packet Radio Service	通用分组射频系统
GSM	Global Standard for Mobile Communications	全球标准移动通信系统
HR	Half Rate	半速率
HSDPA	High Speed Downlink Packet Access	高速下行分组接入
HSUPA	High Speed Uplink Packet Access	高速上行分组接入
IEC	International Electrotechnical Commission	国际电工技术委员会
IMEI	International Mobile Equipment Identity	国际移动设备标识
I/O	Input/Output	输入/输出
ISO	International Standards Organization	国际标准化组织
ITU	International Telecommunications Union	国际电信联盟
kbits	kbits per second	千比特每秒
LED	Light Emitting Diode	发光二极管
M2M	Machine to machine	机器到机器
MO	Mobile Originated	移动台发起的
MT	Mobile Terminated	移动台终止的
NTC	Negative Temperature Coefficient	负温度系数
PC	Personal Computer	个人计算机



PCB	Printed Circuit Board	印制电路板
PCI	Peripheral Component Interconnect	外设部件互连
PCM	Pulse Code Modulation	脉冲编码调制
PCS	Personal Communication System	GSM1900
PDU	Packet Data Unit	分组数据单元
PPP	Point-to-point protocol	点到点协议
PS	Packet Switched	分组交换
QPSK	Quadrature Phase Shift Keying	正交相位移频键控
TCP/IP	Transmission Control Protocol/ Internet Protocol	传输控制协议/互联网协议
UART	Universal asynchronous receiver-transmitter	通用异步收/发器（机）
UIM	User Identified Module	用户识别模块
UMTS	Universal Mobile Telecommunications System	通用移动通信系统
USB	Universal Serial Bus	通用串行总线



Chapter 2. Module review

2.1 Product Introduction

The CWM600 series module is a UMTS HSDPA module with PCI Express Mini Card 1.2 standard interface. It adopts Qualcomm QSC6270 HSPA platform and supports embedded operating systems such as WinCE/Linux. It has functions such as voice, SMS, GPS and high-speed data services. The CWM600 series modules can be used in the following applications:

- ✧ Netbook, notebook
- ✧ PDA、MID
- ✧ GPS navigation
- ✧ Wireless POS machine
- ✧ Wireless advertising, media
- ✧ Wireless routing, switch
- ✧ Remote monitoring
- ✧ Smart meter reading
- ✧ lottery machine
- ✧ Other wireless terminals, etc.

2.2 Module block diagram

The block diagram of the CWM600 module is as follows:

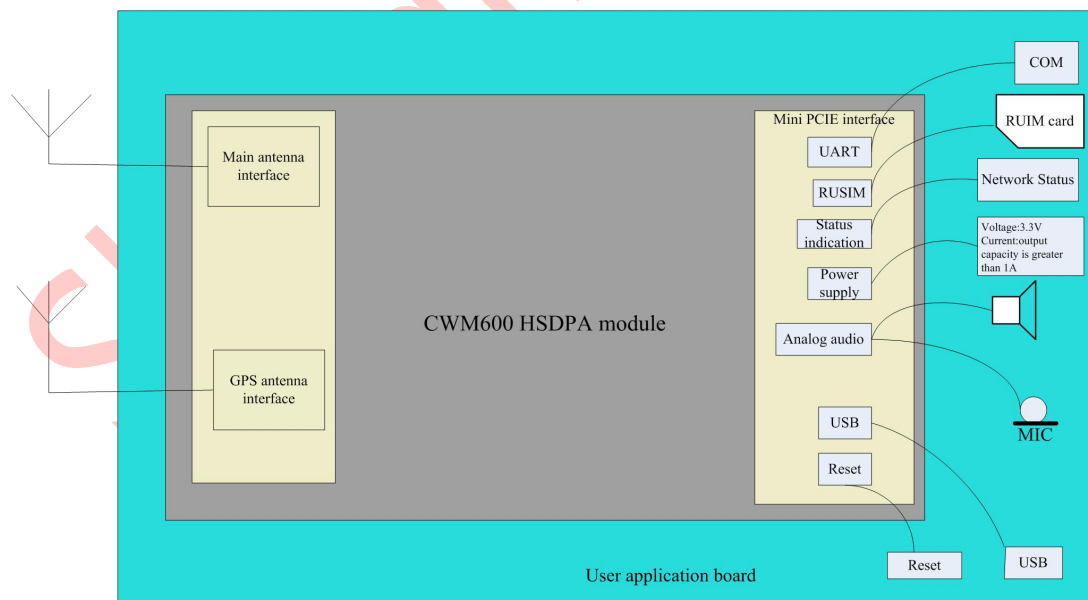

Figure 2-1 CWM600 module block diagram



2.3 Main function of the module

The main functions of the CWM600 module are as follows:

- ✧ Support UMTS/HSDPA/HSUPA Quad Band 850/900/1900/2100 band
- ✧ Support GSM/GPRS/EDGE Quad Band 850/900/1800/1900 frequency band
- ✧ Support for primary/diversity antenna reception
- ✧ Support GPS
- ✧ Support 1 USB 2.0 Highspeed interface
- ✧ Support 1 way USIM card interface (3.0V/1.8V)
- ✧ Support 1 channel UART interface (8 line with flow control function serial port)
- ✧ Support 1 PCM/I2S interface (transmits digital voice)
- ✧ Support 1 pair of differential analog voice input / output
- ✧ Support 2 GPIO and control signals
- ✧ Support 1 LED light control
- ✧ Support standard AT instruction set and YUGA extended AT instruction set



Chapter 3. Technical specifications

3.1 Overall technical indicators

The overall technical specifications of the CWM600 series modules are shown in the following table:

Table 3-1 Overall technical indicators

Technical indicators	Description
External Interface	Mini PCI Express interface : PCI Express Mini Card 1.2standard
Working frequency	UMTS/HSDPA: Quad band, 850/900/1900/2100MHz GSM/GPRS/EDGE: Quad band, 850/900/1800/1900MHz
Data rate	HSDPA: UL 384Kbps/DL 3.6Mbps WCDMA PS: UL 384kbps/DL 384kbps WCDMA CS: UL 64kbps/DL 64kbps EDGE: UL 236.8kbps/DL 236.8kbps GPRS: UL 53.6kbps/DL 53.6kbps GSM CS: UL 9.6kbps/DL 9.6kbps
Maximum transmit power	Class 4 (+33dBm \pm 2dB) for EGSM/GPRS 850 Class 4 (+33dBm \pm 2dB) for EGSM/GPRS 900 Class 1 (+30dBm \pm 2dB) for GSM/GPRS 1800 Class 1 (+30dBm \pm 2dB) for GSM/GPRS 1900 Class E2 (+27dBm \pm 2dB) for EDGE 850 Class E2 (+27dBm \pm 2dB) for EDGE 900 Class E2 (+26dBm \pm 2dB) for EDGE 1800 Class E2 (+26dBm \pm 2dB) for EDGE 1900 Class 3 (+24dBm +1/-3dB) for UMTS 2100, WCDMA FDD BdI Class 3 (+24dBm +1/-3dB) for UMTS 1900, WCDMA FDD BdII Class 3 (+24dBm +1/-3dB) for UMTS 900, WCDMA FDD BdVIII Class 3 (+24dBm +1/-3dB) for UMTS 850, WCDMA FDD BdV
Operating Voltage	3.3~4.2V,Recommended value 3.3V
Working current	Off: <10uA
	Standby: <3mA
	Maximum average: 1000mA
Size	51mm \times 30mm \times 2.6mm
Operating system	Windows 2000 Windows XP 32/64 Windows Vista 32/64 WinCE



		Linux
Weight		20g
Temperature	Normal operating temperature	-30°C ~ +70°C (Full parameter)
	Extended working temperature	-40°C ~ +85°C (Feature)
	storage temperature	-55°C ~ +125°C
Humidity		5% ~ 95%

3.2 Radio frequency indicator

The RF indicators of the CWM600 module are shown in the following table:

Table 3-2 Radio frequency indicator

	Upstream	Down	Power	Receiving sensitivity
GSM	824~849MHz	869~894MHz	33±2dBm	<-108.5dBm
	880~915MHz	925~960MHz	33±2dBm	<-108.5dBm
	1710~1785MHz	1805~1880MHz	30±2dBm	<-108.5dBm
	1850~1910MHz	1930~1990MHz	30±2dBm	<-108.5dBm
WCDMA	824~849MHz	869~894MHz	24+1/-3dBm	<-109dBm
	880~915MHz	925~960MHz	24+1/-3dBm	<-109dBm
	1850~1910MHz	1930~1990MHz	24+1/-3dBm	<-107dBm
	1920~1980MHz	2110~2170MHz	24+1/-3dBm	<-107dBm

3.3 Power Supply DC Characteristics

3.3.1 Power/IO Level Characteristics

The DC characteristics and IO level characteristics of the CWM600 series module power supply are shown in the following table:

Table 3-3 Power/IO Level DC Characteristics

Parameter	Description	Min	Typical	Max	Unit
VCC	Module input power	3.3	3.3	4.2	V
VIH	Input high level	0.65*VDDIO		VDDIO+0.3	V
VIL	Input low level	-0.3		0.35*VDDIO	V
VOH	Output high level	VDDIO-0.45		VDDIO	V
VOL	Output low level	0		0.45	V
CIN	Input capacitance	-		7	pF

Here VDDIO = 2.6V.

Note: The power-on time of any interface of the module must not be prior to the boot time of the module. Otherwise, it may cause the module to be abnormal or damaged.



3.32 Working current

The operating current of the CWM600 series modules is shown in the following table:

Table 3-4 Working current of CWM600 series module

WCDMA parameter description		Average value	Unit
Voltage		3.3	V
Sleep Mode	@DRX=6		mA
	@DRX=8		mA
	@DRX=9		mA
IDLE Mode	@DRX=6 Mode 1		mA
	@DRX=6 Mode 2		mA
	@DRX=6 Mode 3		mA
	@DRX=6 Mode 4		mA
UMTS Data transfer	Band I @+10dBm		mA
	Band I @+23dBm		mA
	Band II @+10dBm		mA
	Band II @+23dBm		mA
	Band VIII @+10dBm		mA
	Band VIII @+23dBm		mA
HSDPA Data transfer	Band I @+10dBm		mA
	Band I @+23dBm		mA
	Band II @+10dBm		mA
	Band II @+21dBm		mA
	Band VIII @+10dBm		mA
	Band VIII @+23dBm		mA

Note: Mode 1: UART Suspend/USB Suspend;
 Mode 2: UART Suspend/USB Active;
 Mode 3: UART Active/USB Suspend;
 Mode 4: UART Active/USB Active



Chapter 4 Interface definition

The CWM600 module interface definition is shown in the following table:

Table 4-1 Interface definition

Pin	Standard Pin definition	Pin definition	I/O properties	Description
1	WAKE#	MIC_P	Analog input	Analog audio input positive terminal (optional feature)
2	3.3Vaux	VCC_3V3	Power input	3.3V main power supply
3	COEX1	MIC_N	Analog input	Analog audio input negative terminal (optional function)
4	GND	GND		Ground
5	COEX2	EAR_P	Analog output	Analog audio output positive terminal (optional feature)
6	1.5V	NC		Unused
7	CLKREQ#	EAR_N	Analog output	Analog audio output negative terminal (optional function)
8	UIM_PWR	VREG_USIM	Power Output	USIM card power supply
9	GND	GND		Ground
10	UIM_DATA	USIM_DATA	Two way	USIM card data
11	REFCLK-	UART1_RXD	Input	UART1 data reception (optional function)
12	UIM_CLK	USIM_CLK	Output	USIM card clock
13	REFCLK+	UART1_TXD	Output	UART1 data transmission (optional function)
14	UIM_RESET	USIM_RESET	Output	USIM card reset
15	GND	GND		Ground
16	UIM_Vpp	NC		Unused
17	Reserved	UART1_RI_N	Output	UART1 ringing indication (optional function)
18	GND	GND		Ground
19	Reserved	GPIO1	Two way	General purpose input and output signal 1 (optional function), 2.6V/1.8V
20	W_DISABLE#	W_DISABLE_N	Input	RF inhibit control, "low" active (optional function)
21	GND	GND		Ground
22	PERST#	RESIN_N	Input	Reset control, "low" is valid
23	PERn0	UART1_CTS_N	Input	UART1 is ready to send(optional function)
24	3.3Vaux	VCC_3V3	Power input	3.3V auxiliary power supply



				(optional function)
25	PERp0	UART1_RFR_N	Output	UART1 request to send(optional function)
26	GND	GND		Ground
27	GND	GND		Ground
28	1.5V	NC		Unused
29	GND	GND		Ground
30	SMB_CLK	WAKE_OUTPUT_N	Output	Host wakeup (optional feature)
31	PETn0	UART1_DTR_N	Input	UART1 DTE is ready (optional feature)
32	SMB_DATA	WAKE_INPUT_N	Input	Module wakeup (optional feature)
33	PETp0	UART1_DCD_N	Output	UART1 carrier detection (optional feature)
34	GND	GND		Ground
35	GND	GND		Ground
36	USB_D-	USB_D-	Two way	USB data cable -
37	GND	GND		Ground
38	USB_D+	USB_D+	Two way	USB data cable +
39	3.3Vaux	VCC_3V3	Power input	3.3V main power supply
40	GND	GND		Ground
41	3.3Vaux	VCC_3V3	Power input	3.3V main power supply
42	LED_WWAN#	LED_WWAN_N	Current input	Work status light control, "low" effective
43	GND	GND		Ground
44	LED_WLAN#	I2C_SDA	input	I2C data reception (optional function), default 2.6V, (1.8V optional)
45	Reserved	PCM_CLK	Two way	PCM clock (optional function), default 2.6V, (1.8V optional)
46	LED_WPAN#	I2C_SCL	Output	I2C clock (optional function), default 2.6V, (1.8V optional)
47	Reserved	PCM_DOUT	Two way	PCM data output (optional function), default 2.6V, (1.8V optional)
48	1.5V	NC		Unused
49	Reserved	PCM_DIN	Two way	PCM data input (optional function), default 2.6V, (1.8V optional)
50	GND	GND		Ground



51	Reserved	PCM_SYNC	Two way	PCM sync (optional function), default 2.6V, (1.8V optional)
52	3.3Vaux	VCC_3V3	Power input	3.3V main power supply

Note: (optional feature) indicates that support or no support can be selected by resistor soldering inside the CWM600 series module.

Shanghai Yuge



Chapter 5. Main function interface description

5.1 UART interface (optional function)

Table 5-1 UART Interface Definition

Pin	Signal name	I/O properties	High value	Description
11	UART1_RXD	Input	2.6V/1.8V	UART1 data reception
13	UART1_TXD	Output	2.6V/1.8V	UART1 data transmission
17	UART1_RI_N	Output	2.6V/1.8V	UART1 ringing indication
23	UART1_CTS_N	Input	2.6V/1.8V	UART1 is ready to send
25	UART1_RFR_N	Output	2.6V/1.8V	UART1 request to send
31	UART1_DTR_N	Input	2.6V/1.8V	UART1 DTE is ready
33	UART1_DCD_N	Output	2.6V/1.8V	UART1 carrier detection
	GND			Ground

The UART1 interface supports a 7-wire serial protocol with a maximum speed of 4Mbps. The UART1 interface supports the following features:

- ✧ Software download upgrade
- ✧ Data communication
- ✧ AT Command
- ✧ Bluetooth

When the UART interface is directly connected to the microprocessor, the reference design is as follows. If the 3-wire connection is used, the RTS and CTS should be shorted. It should be noted that if the levels on both sides do not match, a level shifting device can be connected in series on the signal line or a bidirectional Schottky diode can be added.

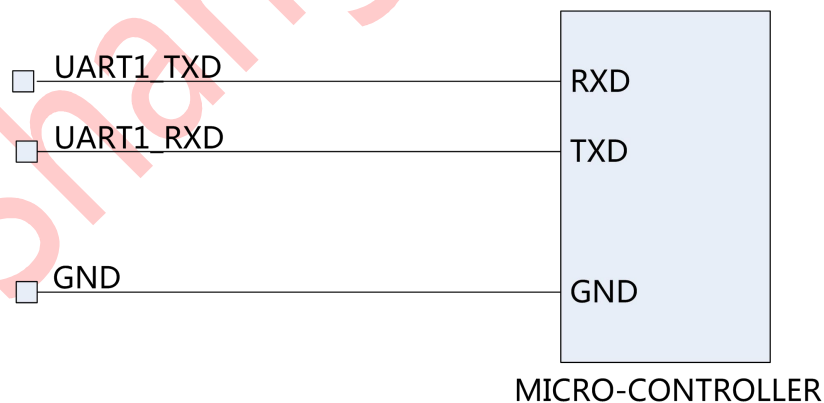

Figure 5-1 UART interface and microprocessor connection reference design

The UART interface can also be connected to the standard RS232-C interface via an RS232 level shifting chip.

The MAX3232 chip is recommended when using a 4-wire serial port. The reference design is as follows:

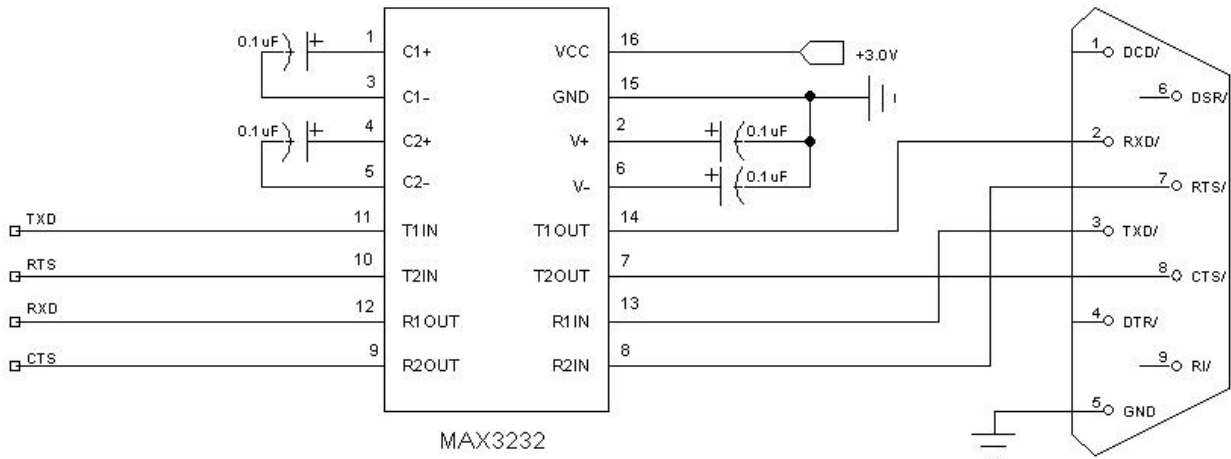

Figure 5-2 Five-wire serial port reference design

The MAX3238 chip is recommended when using an 8-wire serial port. The reference design is as follows:

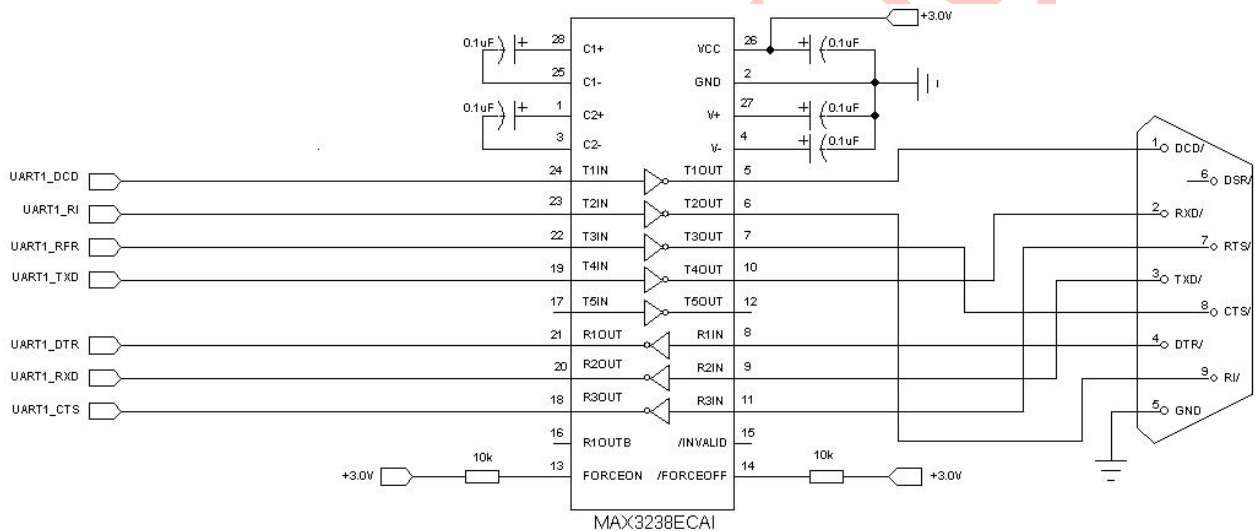

Figure 5-3 8-wire serial port reference design

5.2 USB interface

Table 5-2 USB Interface Definition

Pin	Signal name	I/O properties	High value	Description
36	USB_D-	Two way	3.3V	USB data cable -
38	USB_D+	Two way	3.3V	USB data cable +
	GND			Ground

The USB interface supports USB 2.0 Fullspeed and Low-speed. Note that CWM600 can only be a slave device.

The USB interface supports the following features:

- ✧ Software download upgrade
- ✧ Data communication
- ✧ AT Command



The USB interface reference design is as follows:

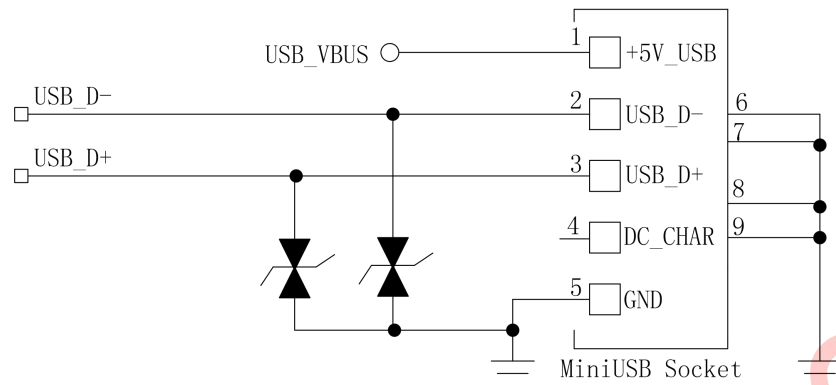

Figure 5-4 USB interface reference design

Since the USB2.0 High speed speed can be up to 480Mbps, you need to pay attention to the following points when designing the motherboard:

1. USB socket needs to meet the USB2.0 High speed requirements;
2. The USB trace needs to be controlled to a 90Ω characteristic impedance;
3. If the ESD protection device is added to the data line, the junction capacitance needs to be less than 1pF;

5.3 PCM interface (optional feature)

Table 5-3 PCM Interface Definition

Pin	Signal name	I/O properties	High value	Description
45	PCM_CLK	Two way	2.6V/1.8V	PCM clock
47	PCM_DOUT	Two way	2.6V/1.8V	PCM data output
49	PCM_DIN	Two way	2.6V/1.8V	PCM data input
51	PCM_SYNC	Two way	2.6V/1.8V	PCM synchronization
	GND			Ground

This interface is a PCM/I2S interface and can support the following functions:

- ✧ Bluetooth
- ✧ Codec interface
- ✧ DAC/ADC interface

The following figure shows an application of the PCM interface for digital voice transmission. It is converted to analog voice by an external Codec chip, and then connected to the MIC and RECEIVER.

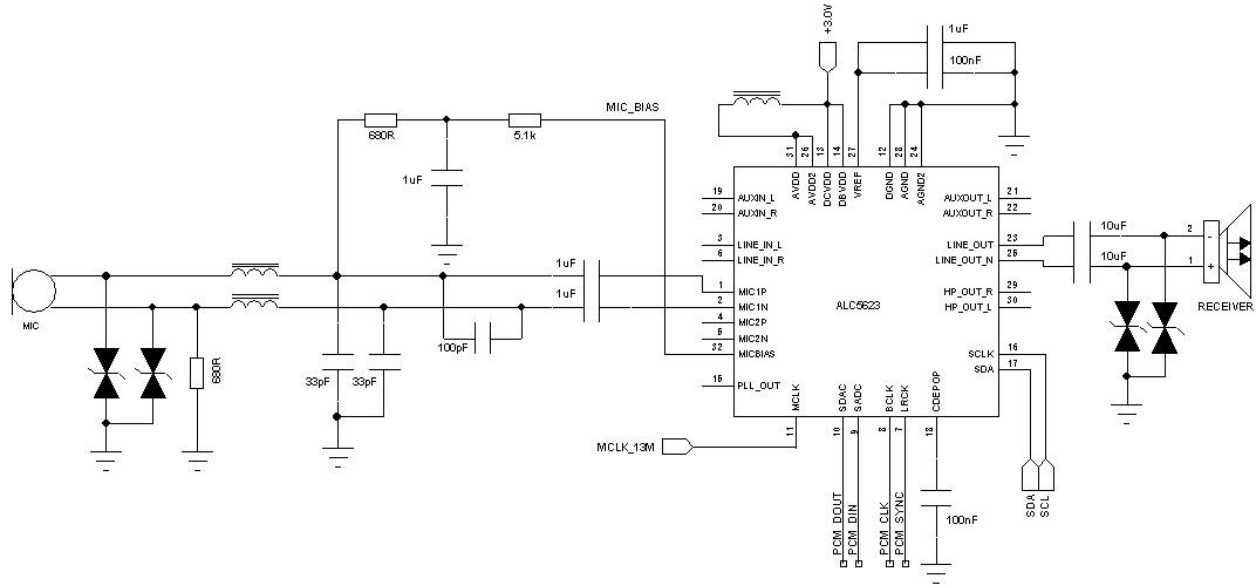

Figure 5-5 PCM digital voice application reference design

5.4 AUDIO interface

Table 5-4 AUDIO Interface Definition

Pin	Signal name	I/O properties	High value	Description
1	MIC_P	Analog input		Audio input positive end
3	MIC_N	Analog input		Audio input negative
5	EAR_P	Analog output		Audio output positive end
7	EAR_N	Analog output		Audio output negative
	GND			Ground

The AUDIO interface provides an audio input and output interface in differential mode. The MIC bias voltage and DC blocking capacitors are already provided inside the module, so the external design is no longer needed. The road audio output can drive a 32 ohm receiver.

The differential line of the differential audio interface should pay attention to the parallel equidistance in the PCB design. The length of the trace should be as short as possible. The filter circuits on both sides should be as symmetrical as possible. The positive and negative differential signals should be as close as possible. The audio input and audio output need to be separated to prevent crosstalk, while away from power, RF, antenna and other circuits. In addition, ESD protection devices are recommended at the MIC, RECEIVER/SPEAKER interfaces.

The reference design of the differential audio input and output interface is as follows:

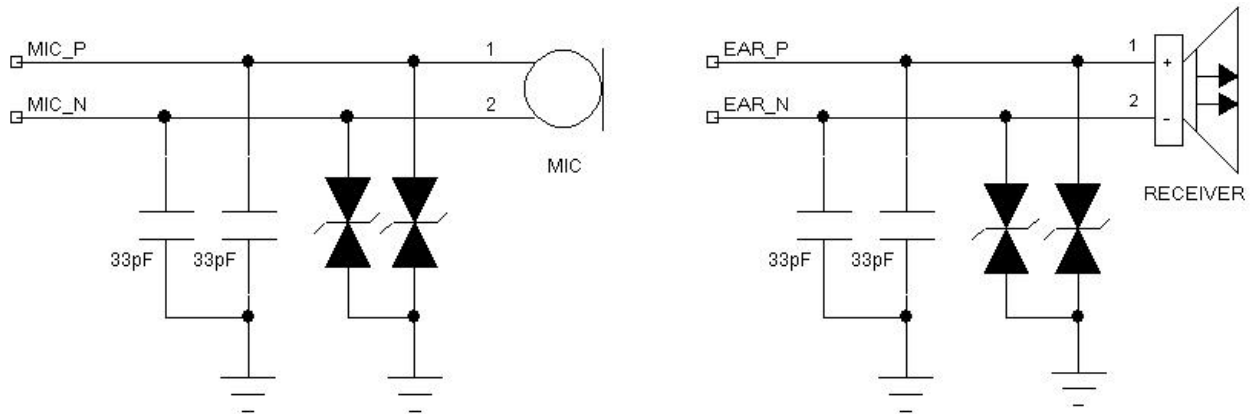

Figure 5-6 Differential Audio Interface Reference Design

The differential audio channel can also work in single-ended mode, such as an external headphone jack. The single-ended audio interface is preferably packaged on the outside of the PCB design. The audio input and the audio output need to be separated to prevent crosstalk. At the same time, keep away from power, RF, antenna and other circuits. In addition, it is recommended to add ESD protection devices at the interface.

The reference design diagram for the single-ended audio interface is as follows:

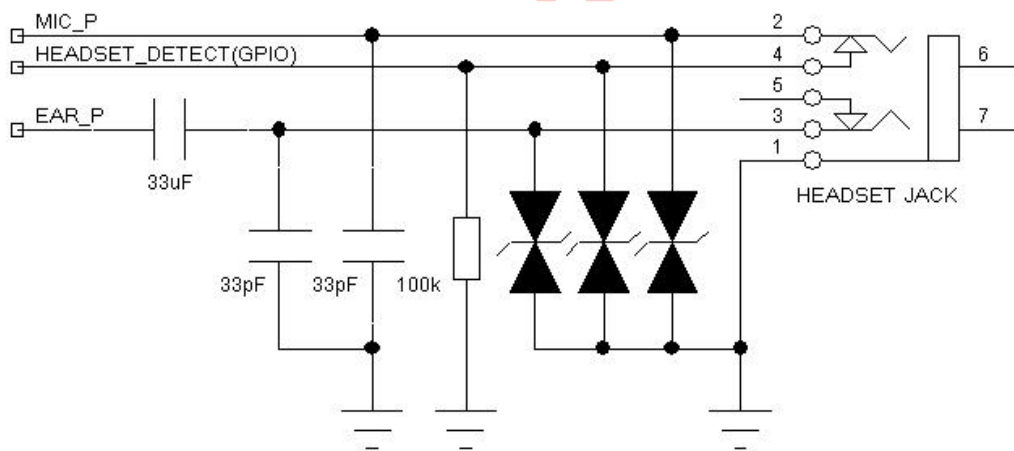

Figure 5-7 Single-ended audio interface reference design

5.5 USIM card interface

Table 5-5 USIM card interface definition

Pin	Signal name	I/O properties	High value	Description
8	VREG_USIM	Output	1.8V/2.85V	USIM card power supply
10	USIM_DATA	Two way	1.8V/2.85V	USIM card data
12	USIM_CLK	Output	1.8V/2.85V	USIM card clock
14	USIM_RESET	Output	1.8V/2.85V	USIM card reset
	GND			Ground



The CWM600 module can be connected to a 3.0V/1.8V USIM card and can be automatically detected. It is recommended to connect 33 μ capacitors between USIM_CLK, USIM_DATA, USIM_RESET and GND to filter out the interference of RF signals, and connect 33ohm resistors in series on UIM_CLK, USIM_DATA and USIM_RESET. Also, be careful to place the ESD protection device next to the USIM deck.

The USIM card interface reference design diagram is as follows:

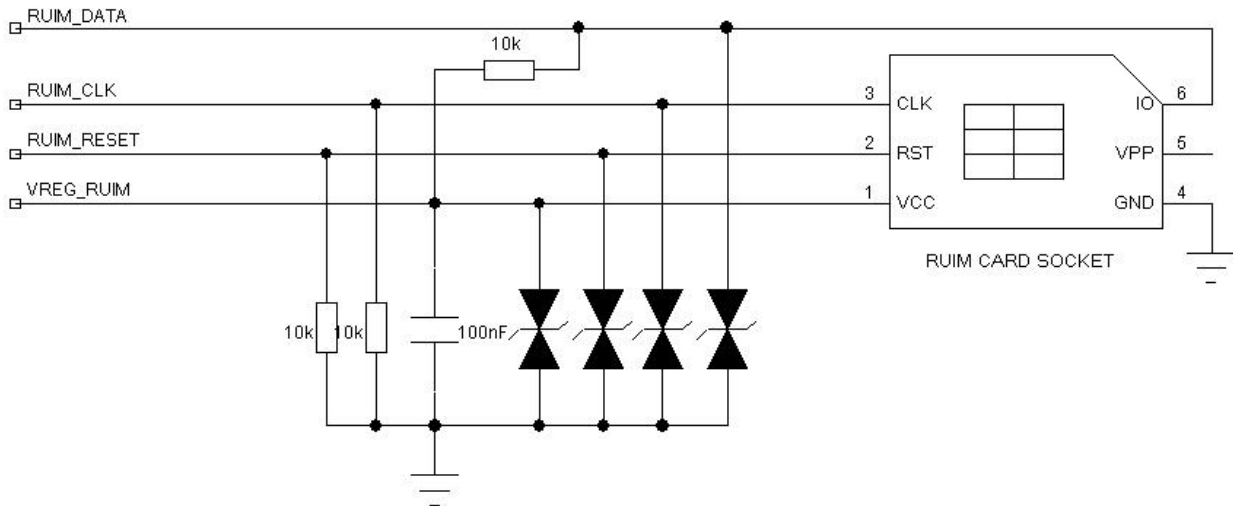

Figure 5-8 USIM card interface reference design

5.6 Control and general purpose I/O interface (optional feature)

Table 5-6 Control and General I/O Interface Definitions

Pin	Signal name	I/O properties	High value	Description
19	GPIO1	Two way	2.6V (1.8V optional)	General purpose input and output signal 1 (default is input, internal pull-up)
20	W_DISABLE_N	Input	2.6V (1.8V optional)	RF is prohibited, "low" is valid, internal pull-up High: normal work Low: No work
22	RESIN_N	Input	1.8V	Reset control, "low" active, internal pullup High: normal operation Low: reset module
30	WAKE_OUTPUT_N	Two way	2.6V (1.8V optional)	General purpose input and output signal (default is input, internal pull-up)
32	WAKE_INPUT_N	Two way	2.6V (1.8V optional)	General purpose input and output signal (default is input, internal pull-up)



42	LED_WWAN_N	Current input	2.6V	Work status light, "low" is valid, default is "high" High: LED light is off Low: LED light on
	GND			Ground

W_DISABLE_N: When the default function of this pin is not used, it can be reused as GPIO.

RESIN_N: The module can be reset by pulling this pin low for 50ms. This pin is sensitive to interference and should be protected when wiring.

LED_WWAN_N: This pin is controlled by SINK type current source mode. The maximum current that can flow in is 40mA. When external LED lamp is connected, the current limiting resistor should be connected in series. The resistance value can be calculated from the rated voltage/rated current of the selected LED lamp.

The reference design of the LED light interface is as follows:

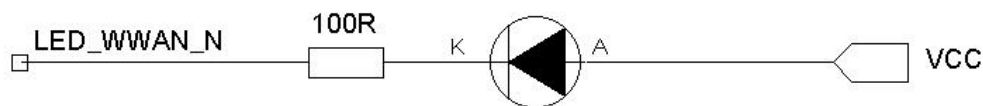

Figure 5-9 LED lamp reference design

LED_WWAN_N is the working status indicator of the CWM600 module, controlled by the module software. The status table is as follows:

Table 5-7 LED_WWAN_N Status Indicator Table

CWM600 working mode	LED display status
Search network	Single flash (cycle is 3s)
Successfully registered network, but in idle state (ie, not in call or data transfer state)	Double flash (cycle is 3s)
Call or data transfer status	Fast flashing (cycle is 0.2s)

5.7 Power interface

Table 5-8 Power Interface Definition

Pin	Signal name	I/O properties	High value	Description
2	VCC_3V3	power input	3.3V	3.3V main power supply
24	VCC_3V3	power input	3.3V	3.3V auxiliary power supply (optional function)
39	VCC_3V3	power input	3.3V	3.3V main power supply
41	VCC_3V3	power input	3.3V	3.3V main power supply
52	VCC_3V3	power input	3.3V	3.3V main power supply
	GND			Ground



The CWM600 series module receives the 3.3V power supply from the outside (accuracy is $\pm 9\%$). The maximum average power consumption of the module is about 1000mA. It is recommended to use LDO or switching power supply of 1.5A or above. In order to maintain the instantaneous voltage stability during operation, it is recommended to add several large storage capacitors, such as 220uF tantalum capacitors, to the power port of the motherboard.

5.8 Antenna socket interface

The CWM600 series module has two antenna socket interfaces, one is the main antenna socket interface (labeled "M"), and the other is the GPS antenna socket interface (labeled "G"). When selecting an external antenna, be careful to use a 50 ohm characteristic impedance cable and antenna.

Diversity antenna function: Enhance RF received signal quality and improve RF performance.

The CWM600 series module antenna interface is recommended for ESD protection. Connect a 68-100nH inductor to the ground. The reference design is as follows:

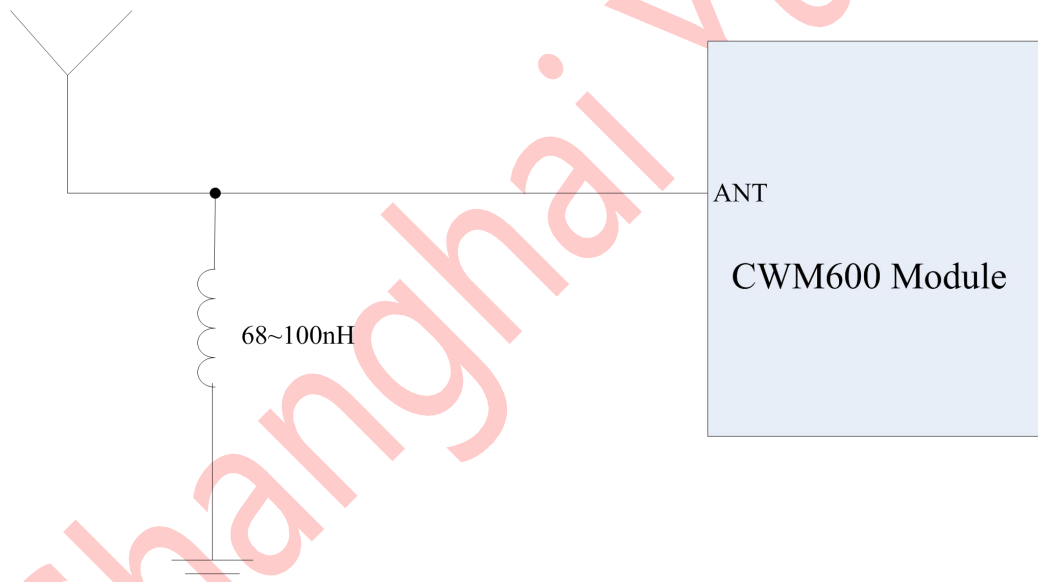

Figure 5-10 Antenna Interface ESD Protection Reference Design



Chapter 6. structure

6.1 Structural size

The structural dimensions of the CWM600 series module are as follows:

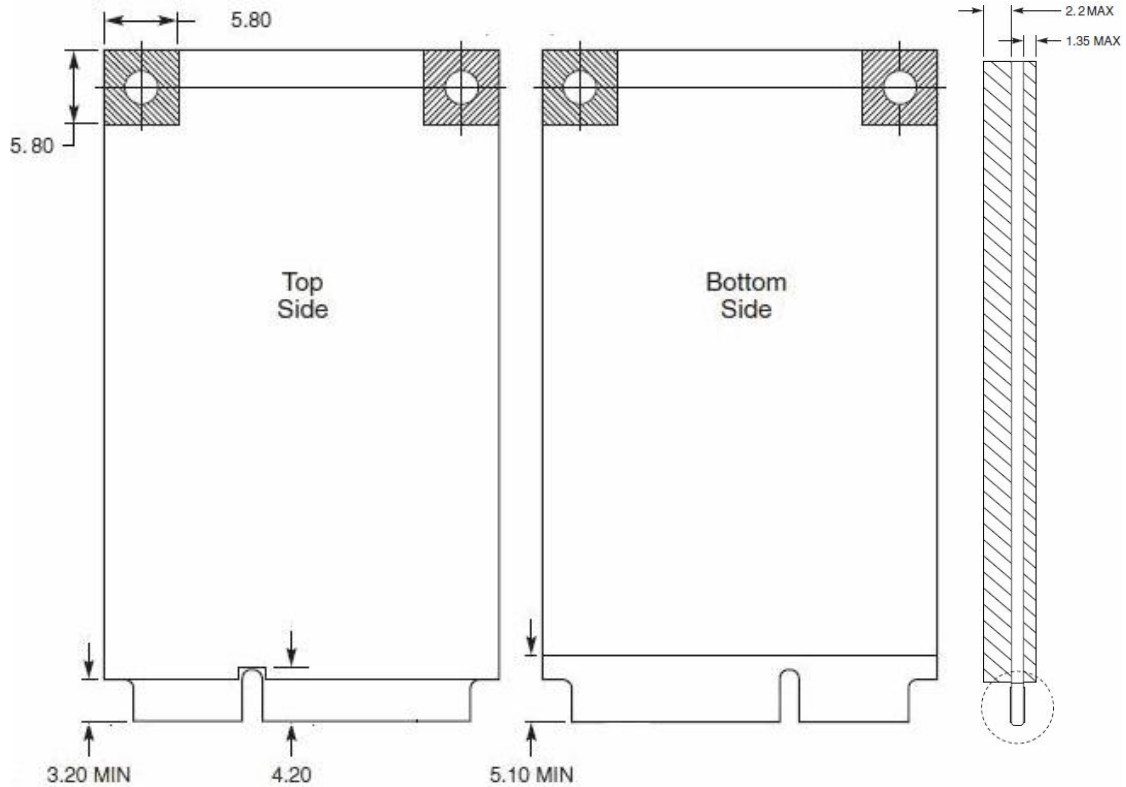

Figure 6-1 CWM600 series module structure size

Specific size: 51mm (length) × 30mm (width) × 2.6mm (height)

6.2 Mini PCI Express connector

The CWM600 series module interface complies with the PCI Express Mini Card 1.2 interface standard, and PCI Express Mini Card connectors conforming to this standard can be used with it, such as Molex's 679100002.

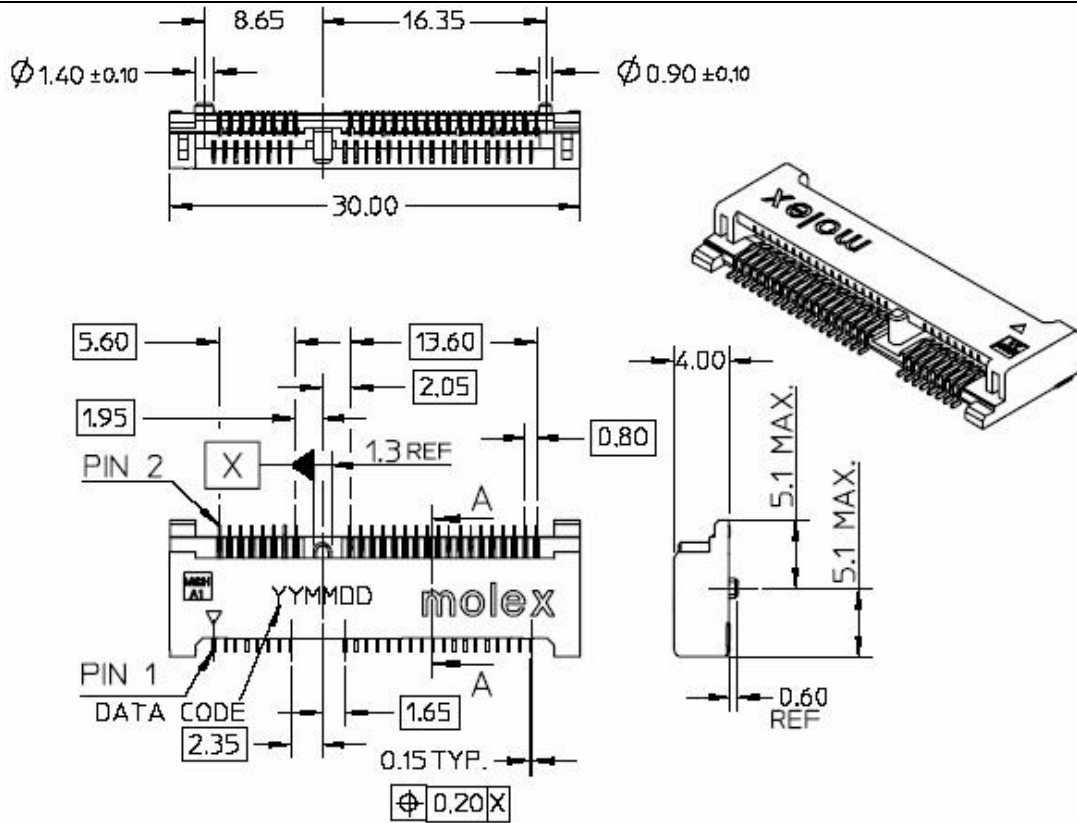

Figure 6-2 PCI Express Mini Card Connector

6.3 RF connector

The RF connector used on the CWM600 series module is the U.FL-R-SMT-1 (10) from HRS.

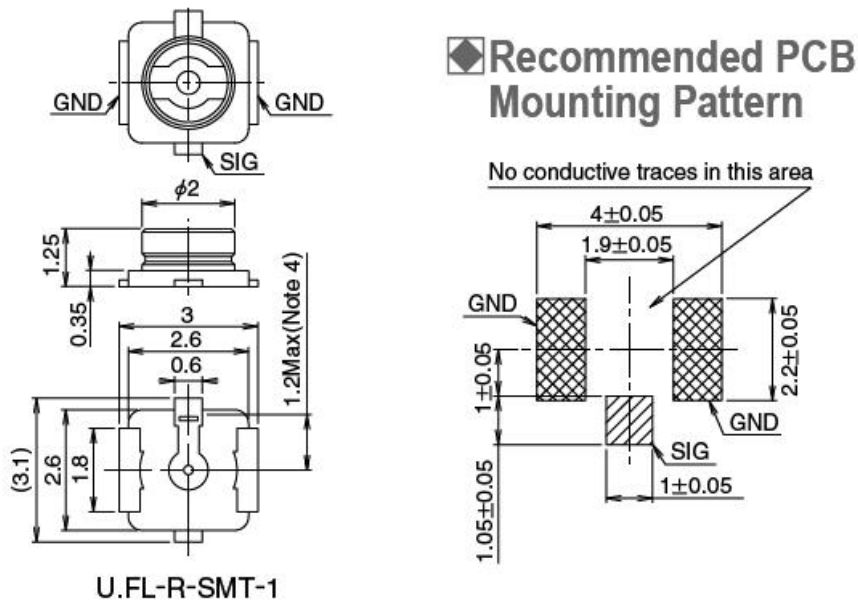

Figure 6-3 Antenna connector size

The RF connector plug for this connector is the U.FL-LP series from HRS.



Part No.	U.FL-LP-040	U.FL-LP-066	U.FL-LP(V)-040	U.FL-LP-062	U.FL-LP-088
Mated Height	2.5mm Max. (2.4mm Nom.)	2.5mm Max. (2.4mm Nom.)	2.0mm Max. (1.9mm Nom.)	2.4mm Max. (2.3mm Nom.)	2.4mm Max. (2.3mm Nom.)
Applicable cable	Dia. 0.81mm Coaxial cable	Dia. 1.13mm and Dia. 1.32mm Coaxial cable	Dia. 0.81mm Coaxial cable	Dia. 1mm Coaxial cable	Dia. 1.37mm Coaxial cable
Weight (mg)	53.7	59.1	34.8	45.5	71.7
RoHS	YES				

Figure 6-4 Antenna connector mating plug

Shanghai YUGE



Chapter 7. Selection guide

CWM600 series module product name and product definition are as follows, CWM600 is the default model, supporting WCDMA2100 frequency band and GSM full frequency band.

When a multi-band module is required, as shown in the following table, each W-band has a code that can be arbitrarily combined according to the required band code. (Note: W850 and W900 cannot be supported at the same time, all models support GSM full frequency by default)

A: represents the WCDMA 2100MHz band

B: represents the WCDMA 1900MHz band

C: represents the WCDMA 900MHz band

D: represents WCDMA 850MHz frequency band

G: Representative with GPS function

Table 7-1 CWM600 module model description

Model	Frequency band	Whether with GPS	Whether to support voice	IO port voltage	Remarks
CWM600 (default model)	UMTS/HSDPA: 2100MHz GSM/GPRS/EDGE: 850/900/1800/1900 MHz	No	Yes	2.6V/ 1.8V	The default interface level is 2.6V. If you need 1.8V interface level, you need to indicate
CWM600 AB	UMTS/HSDPA: 2100/ 1900 MHz GSM/GPRS/EDGE: 850/900/1800/1900 MHz	No	Yes	2.6V/ 1.8V	
CWM600 ABC	UMTS/HSDPA: 2100/1900 /900MHz GSM/GPRS/EDGE: 850/900/1800/1900MHz	No	Yes	2.6V/ 1.8V	
CWM600 G	UMTS/HSDPA:2100MHz GSM/GPRS/EDGE: 850/900/1800/1900MHz	Yes	Yes	2.6V	